

Description VAPELESS sensor

The **VAPELESS** is advanced technology gas detection indoor sensor applied for the full sensing of the Vaping gases exhaust by the electronic cigarettes together with environment temperature and humidity. **VAPELESS** is enclosed in a room sensor box and designed to be ceiling-mounted. **VAPELESS** is powered 5V DC voltage and is enclosed with 3.6 V batteries for the feeding LoRaWAN infrastructure in the sensor. The data transmitted from the sensor is based on Class A LoRaWAN® wireless network.

Sensor has sophisticated **“Pattern Recognition”** AI technology and detects any kind of Vaping gas mix of any kind of Vaping fluids and flavors, even with mixed drugs.



Applications

- Schools, universities
- Hotels
- Banks
- Hospitals
- Industrial facilities, factories
- Public buildings
- Government buildings

Product features

- Indoor Vaping detection
- **Electronic cigarettes, IQOS, marihuana (THC) and classic cigarettes detection**
- LoRaWAN communication
- Computational AI algorithm
- Indoor temperature and humidity sensor
- Configuration over the air
- Pattern recognition technology
- **Auto self-calibration**
- Aggression and Violence Detection

Sensing characteristics

Vaping Index	ranging from 1 to 500 Vaping Index points
Vaping repeatability	<±5 of Vaping Index points
Aggression and Violence Index	ranging from 0 to 10 Aggression Index points
Gunshot Detection (Optional)	A notification is sent upon detecting firearm use
Temperature	-10 to 70 °C
Temperature Accuracy	Max '+/-0.2°C@ 0°C—70°C Max '+/-0.3°C@ -10°C—0°C
VOC Index	ranging from 1 to 500 VOC Index points
VOC repeatability	<±5 of VOC Index points
Humidity	0 to 100 % RH (non-condensing)
Humidity Accuracy	"±/-1.8%RH @20°C, >90% "±/-3%RH @20°C

Preliminary mechanical specification

Weight	Up to 230 g without batteries, up to 290 g with batteries
--------	-----------------------------------------------------------

Dimensions	Up to 146 x 130 x 45 mm
Enclosure	Plastic
Storage Temperature	-40 to 70 °C
Sensor Power Supply	
Battery Type and voltage	2x3.6 V AA Lithium Battery ER14505 AA lithium batteries (3.6V2400mAh/section) And external 5 V DC power supply
Expected Battery Life	<10 years (Depending on configurations and environment)
Sensor logging Function	
Sampling Interval	Configurable via downlink configuration, NFC configuration is optional
Data Upload Interval	Configurable via downlink configuration, NFC configuration is optional
Radio / Wireless specification	
Wireless Technology	LoRaWAN® 1.0.3
Wireless Security	LoRaWAN® End-to-End encryption (AES-CTR), Data Integrity Protection (AES-CMAC)
LoRaWAN Device Type	Class A End-device
Supported LoRaWAN® features	Default - OTAA , Optional - ABP, ADR, Adaptive Channel Setup
Supported LoRaWAN® regions	EU863 – 870 Optional: US902 – 928, EU863 – 870, AU915 – 928, EU433, RU864, IN865
Link Budget	137 dB (SF7) to 151 dB (SF12)
TX Power	14dBm±1dBm (Region specific)
Rx Sensitivity	132 dBm (LoRa, Spreading Factor=12, Bit Rate=293bps) -118 dBm (FSK, Frequency deviation=5kHz, Bit Rate=1.2kbps)
Communication range	10 km (line-of-sight, actual transmission distance depends on the environment)

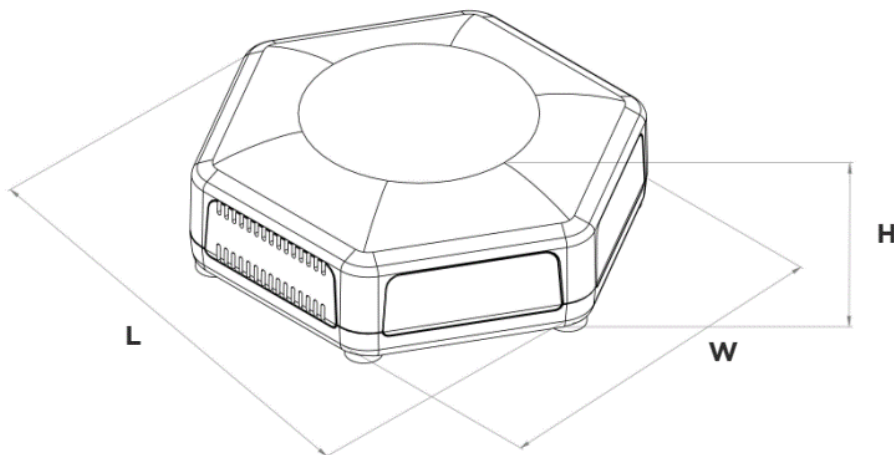
Sensor dimensions:

H: 45 mm
W: 130 mm
L: 146 mm